

Mr. Steven B. Krivit  
New Energy Times

Dear Mr. Krivit:

This responds to your Freedom of Information Act request transferred to the MSFC from NASA HQS on 11/13/2011. You requested slide presentations from the LENR Innovation Forum workshop that took place at NASA Glenn Research Center on Sept. 22, 2011. The portion of your request for Michael Nelson's presentation was forwarded to MSFC for an initial determination. Mr. Nelson's presentation is enclosed in its entirety.

A determination has been made that reproduction costs for this request were minimal. Accordingly, in keeping with NASA's policy to provide the widest practicable dissemination of information concerning its activities, reproduction costs have been waived.

If you have any trouble with opening the file or have any questions concerning your request, please reply to this email or phone me.

Cordially,

Judi A. Hollingsworth

MSFC FOIA Public Liaison Officer



# Overview of Low Energy Nuclear Reactions (LENR) as Implemented by Andrea Rossi and Francesca Piantelli

2011 LENR Workshop at GRC  
September 22, 2011

Michael A. Nelson

MSFC Low Energy Nuclear Reaction (LENR) Space  
Applications Lead (ER22) NASA-MSFC



# Introduction and Background

---



- Bachelors Degree in Industrial and Systems Engineering with University of Alabama in Huntsville
- 29 Years with NASA
  - 19 years in ground and vehicle data systems
    - Space Shuttle Main Engine, Spacelab, Space Telescope, Chandra, Space Station
  - Last 10 years in Propulsion
    - Cobra Rocket Engine, RS84, RS83, SSME, Space Shuttle Main Propulsion Systems, Currently J2X
    - Co-Chair of JANNAF Panel on Rocket Engine Health Management
    - Space Shuttle Propulsion Systems Chief Engineers Board
    - Main Propulsion Systems Hazardous Gas Manager for Shuttle Launches
- Free Energy Investigator (Last 5 years as a hobby)
  - SEARL, Papp Engine, Over unity electric motors, Rossi



## Highlights of Recent History of LENR with Andrea Rossi

---



- January 14, 2011 - Andrea Rossi demonstrated a Nickel-Hydrogen LENR technology that produced steam. Levi coordinated the demo with other University of Bologna professors.
- February 10-11, 2011 – Rossi performs 18 hour test. Reported by Mats Lewan on Feb 23rd in Ny Teknik: "Cold Fusion: 18-Hour Test Excludes Combustion."
- March 16, 2011 - Stremmenos tells Express that Defkalion Green Green "is investing €200 million," ...
- June 14-15, 2011 – Rossi performs a demonstration of a single E-cat for Steve Krivit of New Energy Times at site in Bologna, Italy.
- July 6, 2011 - Defkalion makes public offering of Rossi technology at a price of 40.5 million per factory.



## Highlights of Recent History of LENR with Andrea Rossi

---



- July 14<sup>th</sup>, 2011 – Rossi meets with NASA/MSFC to discuss space applications with his technology and invite NASA to test it
- August 1, 2011 - Deadline for first payment from first potential customer (investor), Defkalion, to Rossi passes.
- August 2-4, 2011 - Rossi meets with new potential investor in Boston, MA
- August 7, 2011 - Rossi issues press release announcing termination of business with Praxen/Defkalion
- September 7, 2011 (4 pm) - Rossi device test for Lewan/Ny Teknik
- September 8, 2011 - Rossi meeting with next potential customer (investor)



# Technical Interchange Meeting with Andrea Rossi on July 14<sup>th</sup>, 2011

---



- Who was in attendance
  - MSFC Chief Engineer's office and Chief Technologist
  - Propulsion Research Laboratory representatives
  - ER propulsion engineers and interested contractors
  - Representative from Langley office of Chief Scientist
  - Representative from Glenn Research Center
  - Physicists from UAH
  - MSFC Safety Office
- Andrea Rossi came to MSFC with officials from Ampenergo, US Aerospace Contractor, other interested parties
  - Andrea traveled at no expense to NASA
  - Ampenergo is a US based company that is in partnership with Andrea
  - Andrea and Ampenergo officials took a tour of MSFC prior to the meeting



## Andrea Rossi Existing LENR Implementation...

---



- Uses Nickel powder ground to specific flake sizes to maximize surface area of the Nickel without making flakes that are too small
  - A key difference with Piantelli work (not recommended by Piantelli)
  - Nanosize too small, mm size too large, micron is just right
  - Powder is “enriched” to increase NI-62, NI-64 content
- Powder is contained in a small stainless steel chamber about the size of a D cell flashlight battery
  - 50 grams of Nickel powder required to charge a single cell (Just under one mole of Nickel atoms)
- Chamber is filled with 1 gram of Hydrogen gas at a pressure of 24 atmospheres (approx. 350 psi)
  - Approximately 1 mole of hydrogen atoms is consumed per day
  - Hydrogen assumed to go mono-atomic for reaction



# Andrea Rossi Existing LENR Implementation...

---



- A catalyst facilitates the reaction of the Hydrogen with the Nickel
  - Key to Rossi Reaction
  - Catalyst is consumed in about 6 months time
- The reaction chamber is encapsulated in lead to contain the gamma radiation and convert it into thermal energy
  - Gamma radiation in the 50 to 200 KeV energy band
- A heating element is used to initiate and stabilize the reaction
  - Heat output versus heat input required for reaction has been claimed to be as much as over 400X.





# Andrea Rossi Existing LENR Implementation...



Speculative Rendering of Internal Core of Energy Catalyzer Using Simple Chamber

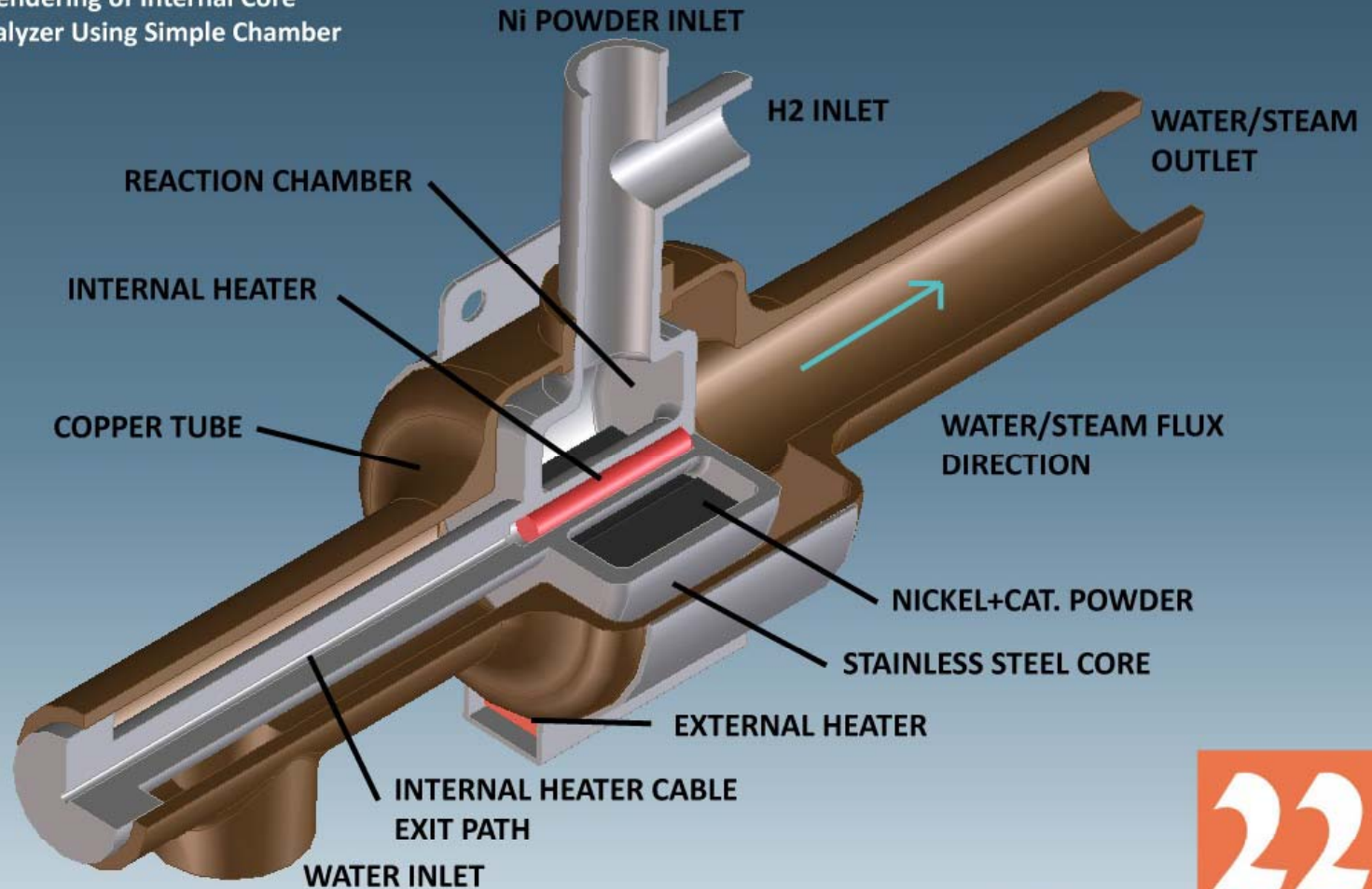

May 2011





# Andrea Rossi Existing LENR Small ECAT Implementation...





# Andrea Rossi Existing LENR Ottoman Size ECAT Implementation...

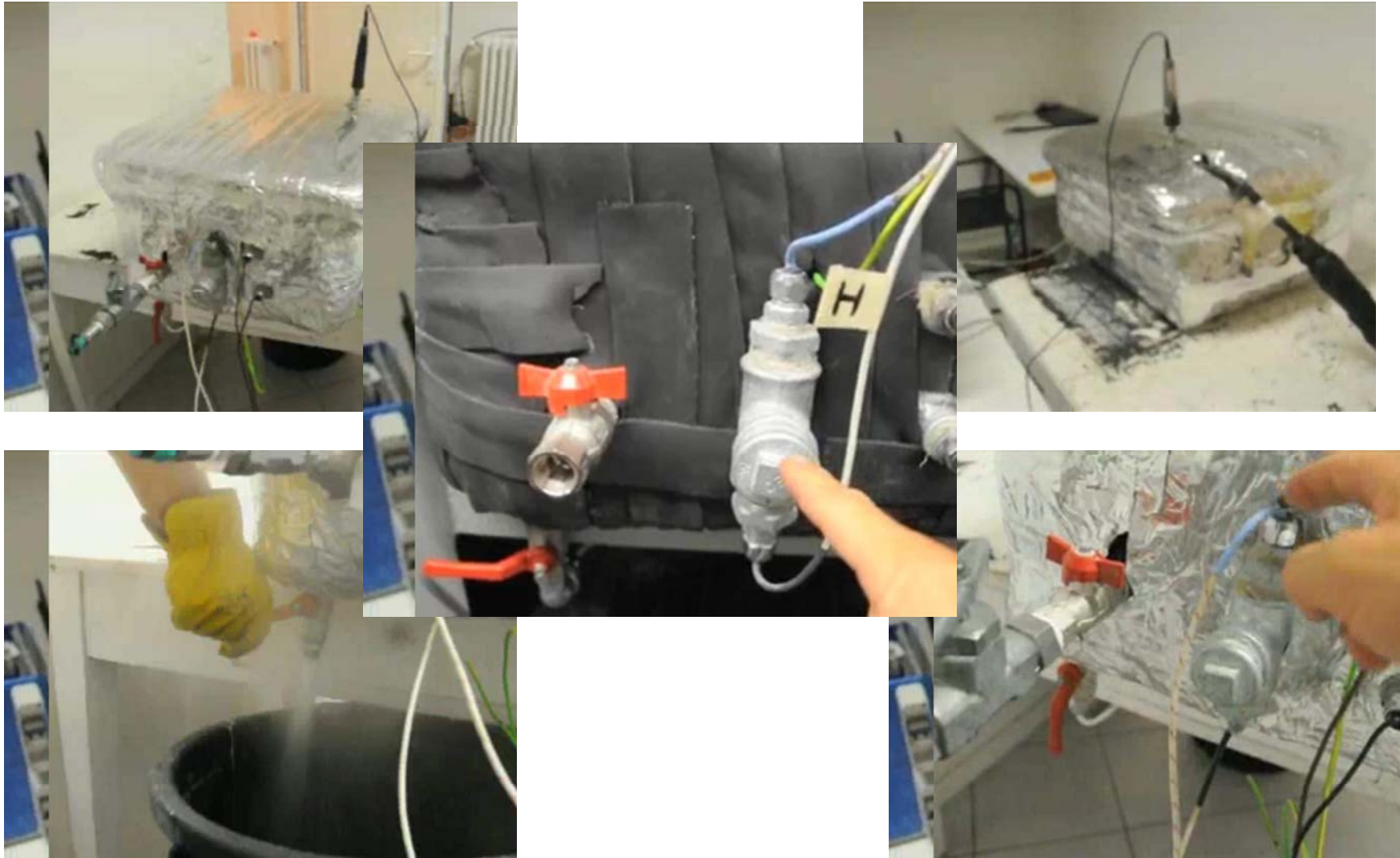



# Andrea Rossi Existing LENR 1 MW Power Plant Implementation...





# Andrea Rossi Existing LENR Is it Nuclear...?



- Criteria for Nuclear Reaction
  - Gamma Radiation
    - Rossi has avoided direct measurement for fear of revealing catalyst
    - To date has only been observed by very few people
    - Cannot rule out spurious signals on Rossi's device
  - Self Sustained mode
    - Claims have been made that this is possible but has never been satisfactorily demonstrated
    - Would need to run for 8 hours or more with a small ECAT and much longer for an Ottoman
  - Long enough duration to rule out chemical reaction
    - 3 or more days for a small ECAT
    - 2 or more weeks for an Ottoman ECAT
    - Several months for a 1 MW plant



# Andrea Rossi Existing LENR Conclusions...

---



- Difficult to rule Rossi out
  - In spite of the low quality demonstrations no one has yet to completely dismiss Rossi's work as a total sham
    - From all accounts he has sunk a personal fortune into this
    - He is not selling shares in a future company
    - He does allow potential investors to kick the tires a bit ... albeit strictly on his terms thus far
  - Endorsed by Focardi and Guiseppi Levi
  - Stay tuned... these next few months will be interesting



## Highlights of History of LENR with Francesca Piantelli

---



- August 16, 1989 – Dr. Francesca Piantelli discovered anomalous heat in a device that he was developing involving hydrogen and a piece of Nickel metal
- February 1990 – Dr. Piantelli saw the anomalous heat for the second time and was able to prevent it from damaging his equipment
- January 1992 – Dr. Piantelli observes a increase in temperature and altered metal surface of a cylindrical Nickel sample after heavy hydrogen loading but no gamma or neutron radiation
- September 1993 – Dr. Piantelli has an experiment increase in temperature in an uncontrolled manner to a temperature in excess of 1450 degrees C.



## Highlights of History of LENR with Francesca Piantelli

---



- October 1993 – Dr. Piantelli along with Dr. R. Habel and Dr. S. Focardi observe an increase in temperature and excess energy of over 90 MJ with altered metal surface of a Nickel plated Nickel alloy cylinder with no gamma or neutron radiation
- September 1994 – Dr. Piantelli along with S. Focardi, V. Gabbani, V. Montalbano, and S. Veronesi observe an increase in temperature and excess energy of over 900 MJ with altered metal surface of a Nickel plated Nickel alloy cylinder with gamma and neutron radiation.
- November 1994 – Dr. Piantelli along with S. Focardi, V. Gabbani, V. Montalbano, and S. Veronesi observe an increase in temperature and excess energy of over 600 MJ of a Nickel plated Nickel alloy cylinder with gamma but no neutron radiation.





## Highlights of History of LENR with Francesca Piantelli

---



- March 1996 – Dr. Piantelli along with S. Focardi, V. Gabbani, V. Montalbano, and S. Veronesi observe an increase in temperature and excess energy of over 38 MJ of a Nickel plane with gamma radiation but no neutron radiation after medium hydrogen loading.
- July 1996 – Dr. Piantelli along with S. Focardi, V. Gabbani, V. Montalbano, and S. Veronesi observe no increase in temperature nor any excess energy of a Nickel plane with gamma radiation but no neutron radiation after very light hydrogen loading.
- June 1996 – Dr. Piantelli along with E. Campari, S. Focardi, V. Gabbani, V. Montalbano, S. Veronesi observe an altered surface of a Nickel alloy cylinder with no gamma radiation or neutron radiation after high hydrogen loading.



## Highlights of History of LENR with Francesca Piantelli

---



- September 1997 – Dr. Piantelli along with E. Campari, S. Focardi, V. Gabbani, V. Montalbano , S. Veronesi observe a temperature increase and 100 MJ of excess energy of a Nickel alloy cylinder with no gamma radiation or neutron radiation after medium hydrogen loading.
- November 1997 – Dr. Piantelli along with S. Focardi, V. Gabbani, V. Montalbano , S. Veronesi observe no temperature increase or excess energy of a Nickel alloy cylinder with gamma radiation but no neutron radiation after low hydrogen loading.
- September 2001 – Dr. Piantelli along with S. Focardi, L. Cattaneo V. Gabbani, V. Montalbano, L. Nosenzo, A. Piazzoli, S. Veronesi observe no temperature increase or excess energy of a Nickel plated Nickel alloy cylinder with no gamma radiation and no neutron radiation after medium hydrogen loading.



## Highlights of History of LENR with Francesca Piantelli

---



- December 2004 – Dr. Piantelli as a result of a collaboration between Siena University and Lumenergia (a firm based in Brescia), moves into a new laboratory located at Colle Val d'Elsa near Siena Italy with 400 square meters of space. The lab features a facility for producing Ni samples for testing.



# Francesca Piantelli LENR Experimental Results

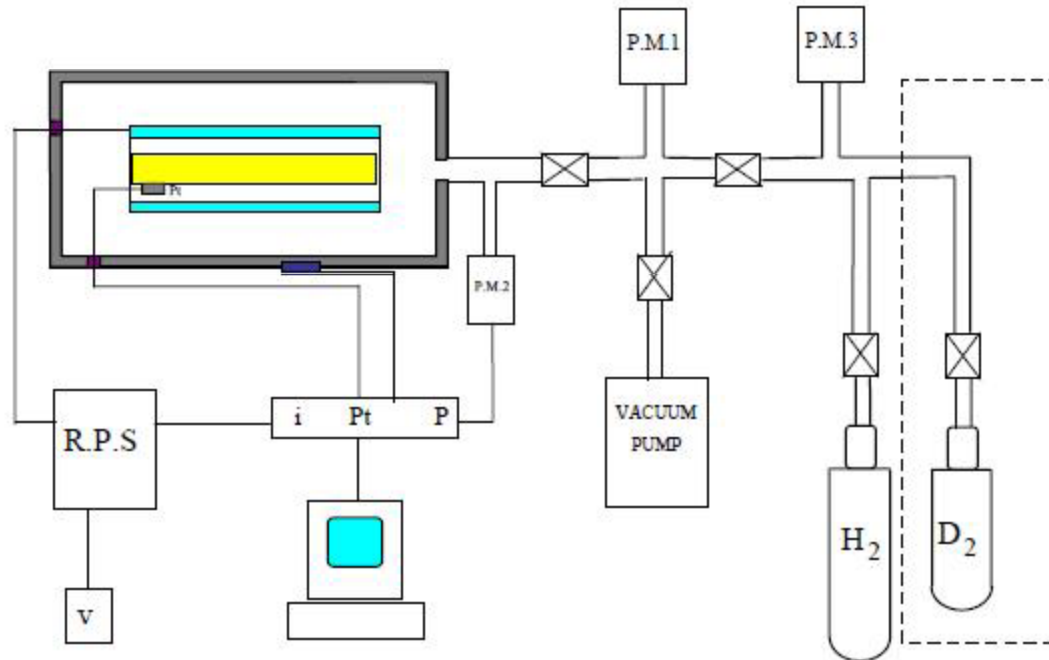
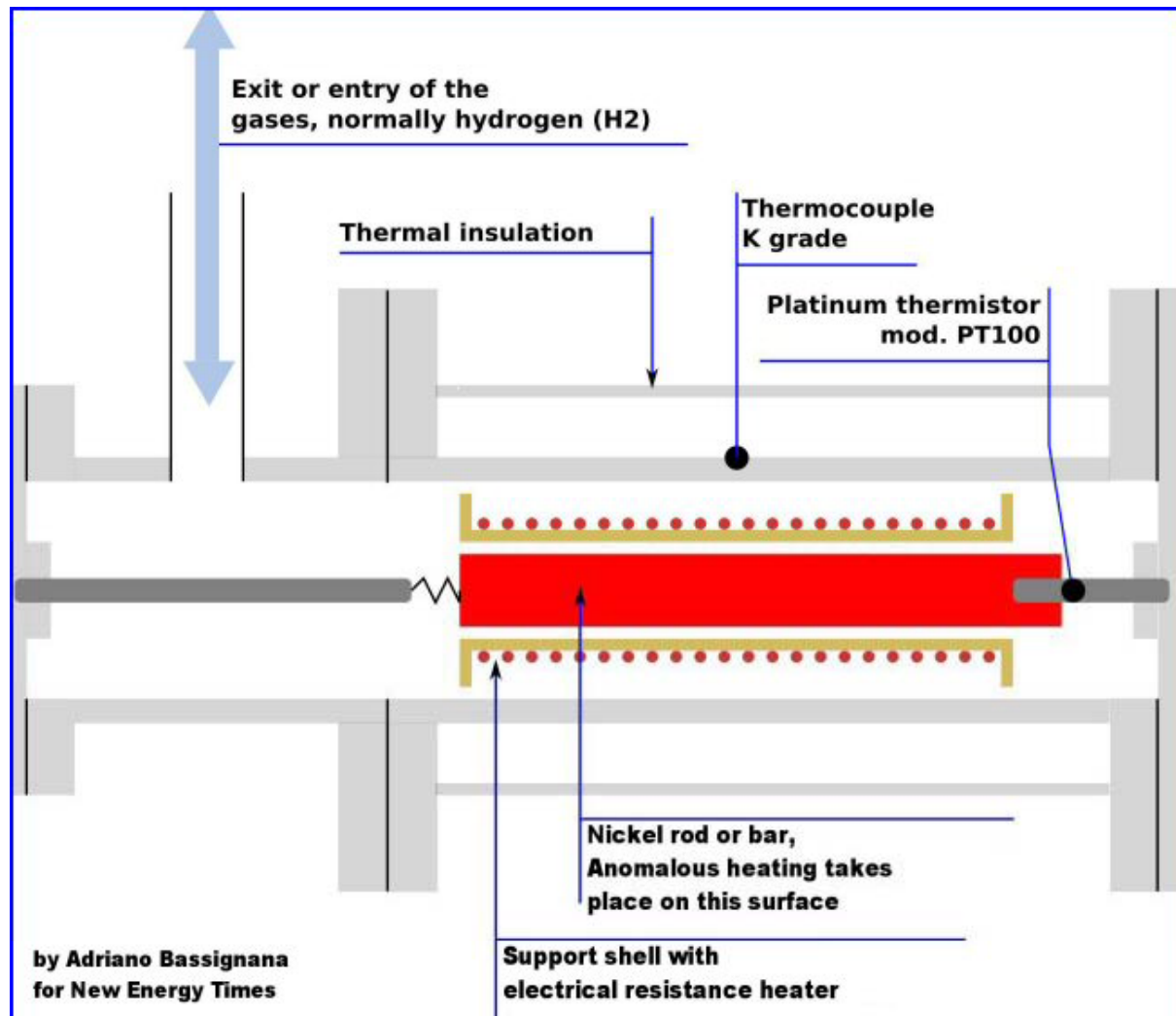

Figure 1. A schematic layout of the experimental setup.



# Francesca Piantelli LENR Experimental Results





# Francesca Piantelli LENR Experimental Results

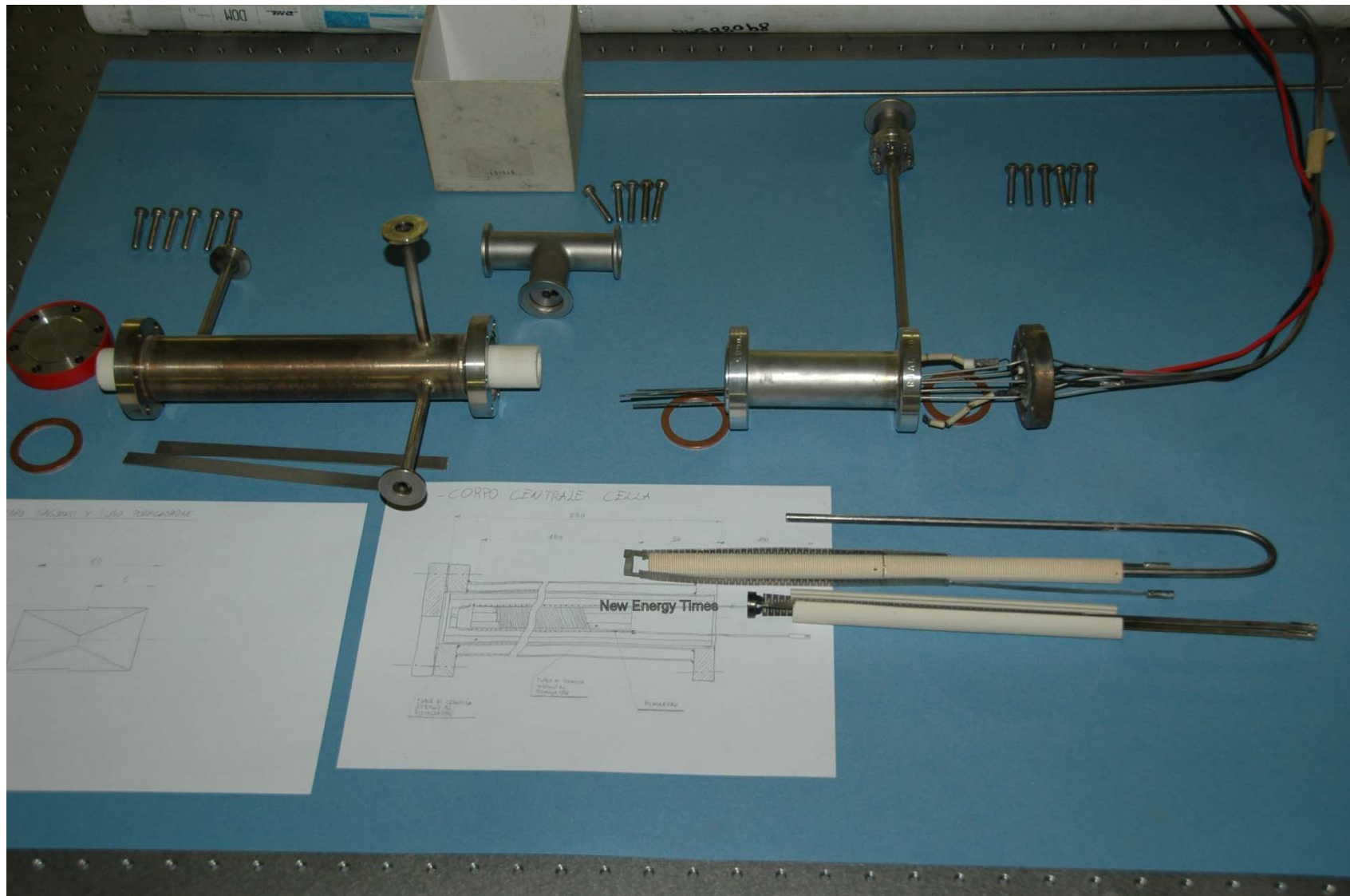



# Francesca Piantelli LENR Experimental Results

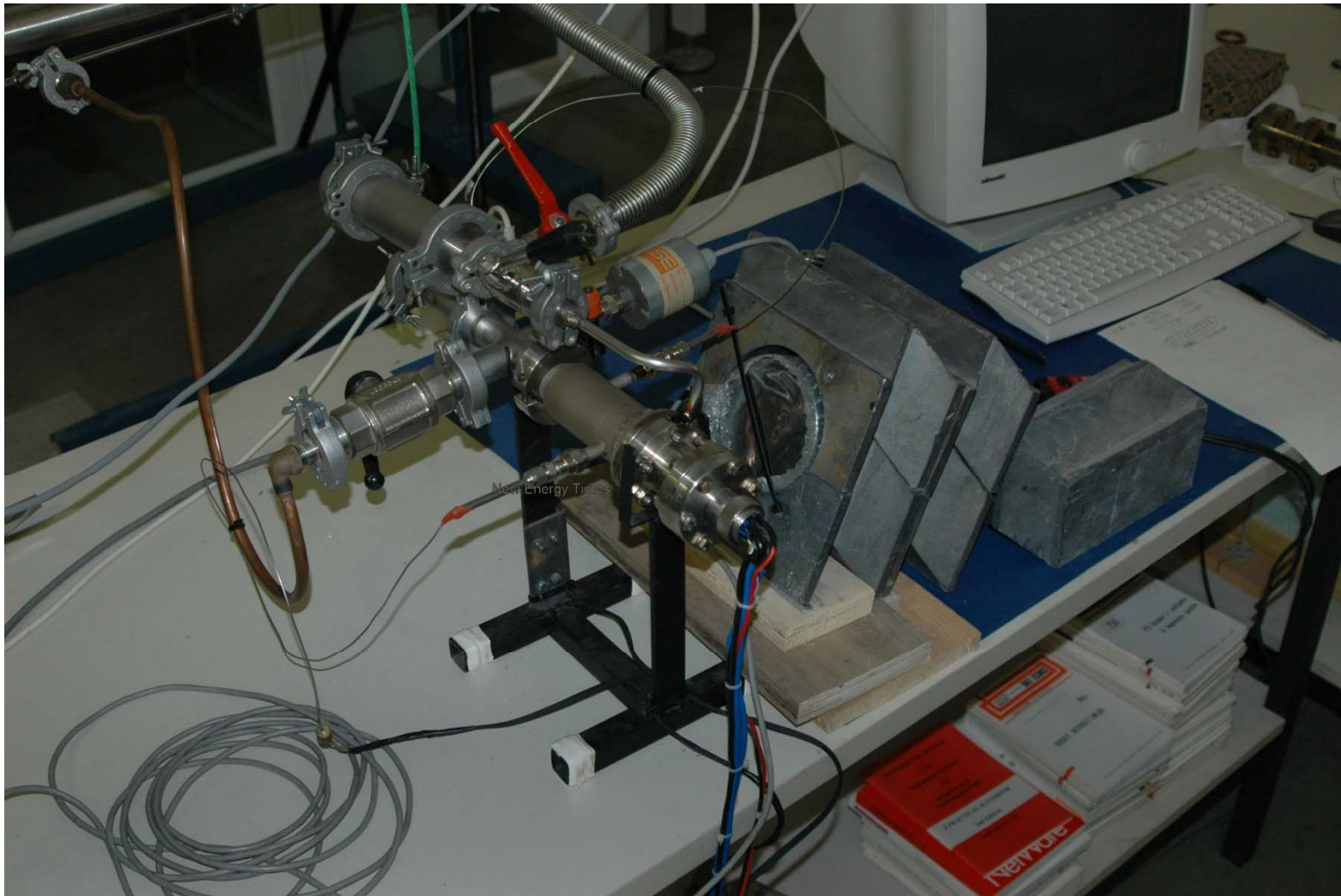
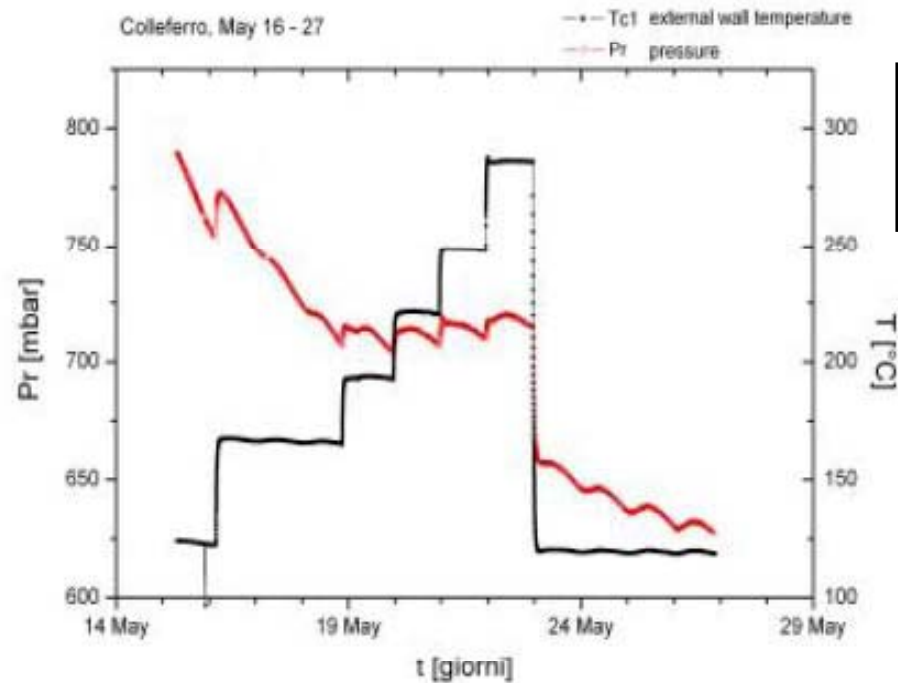

Image Courtesy New Energy Times



# Francesca Piantelli LENR Experimental Results



Hydrogen loading increased when temperature was below 200 degrees C





# Francesca Piantelli LENR Experimental Results

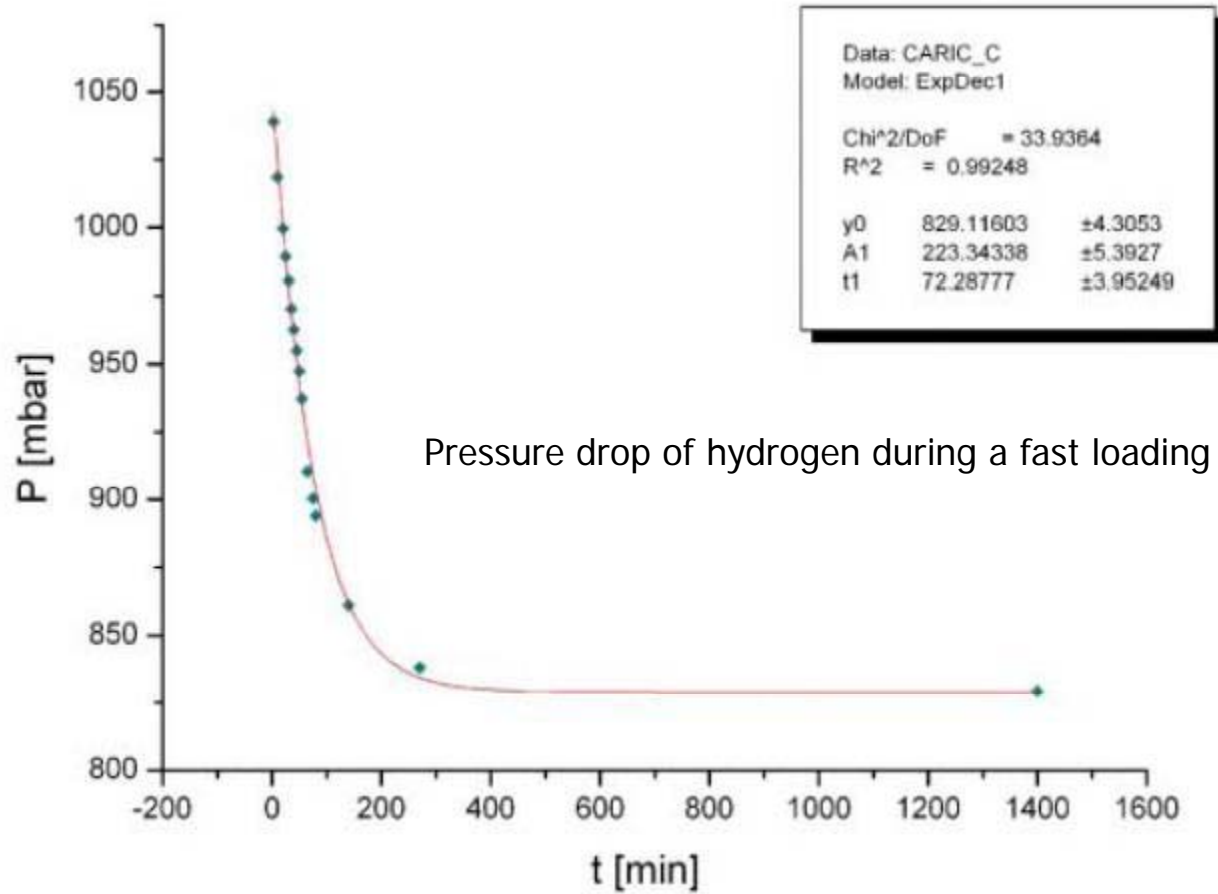



# Francesca Piantelli LENR Experimental Results

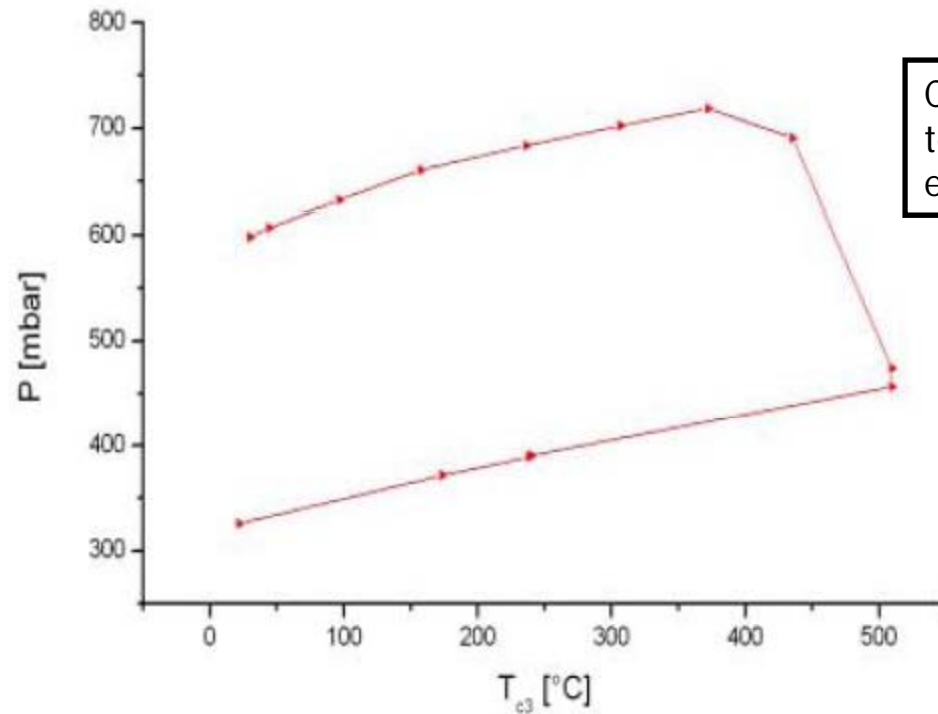

Counterintuitive relationship of pressure temperature once the sample becomes excited.



# Francesca Piantelli LENR Experimental Results

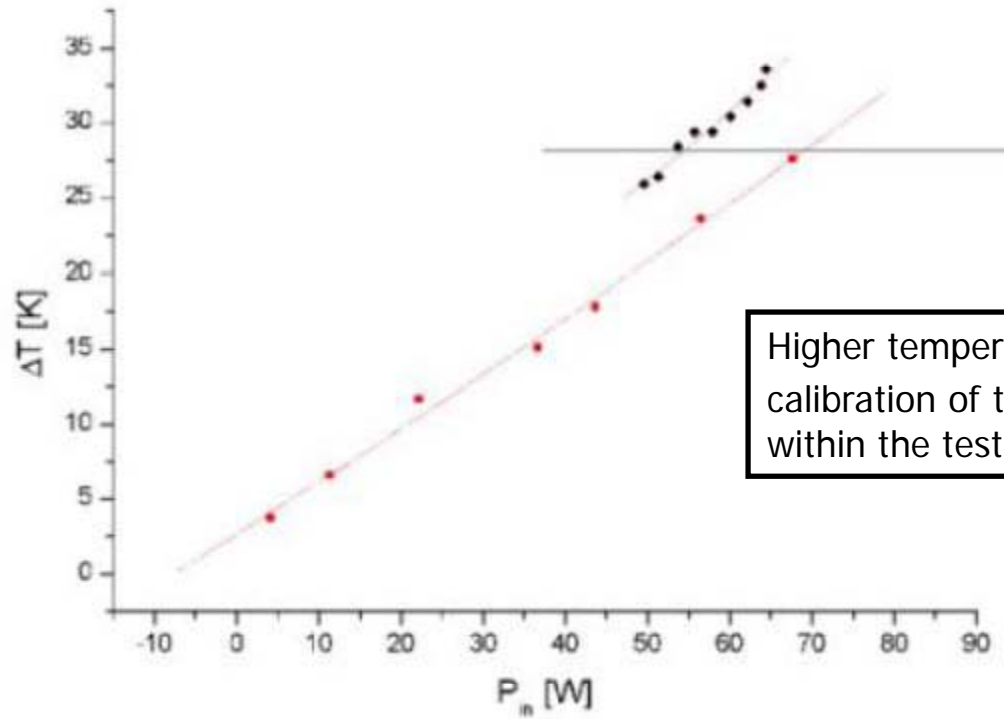

Higher temperature output after calibration of the heating element within the test has been completed



# Francesca Piantelli LENR Experimental Results

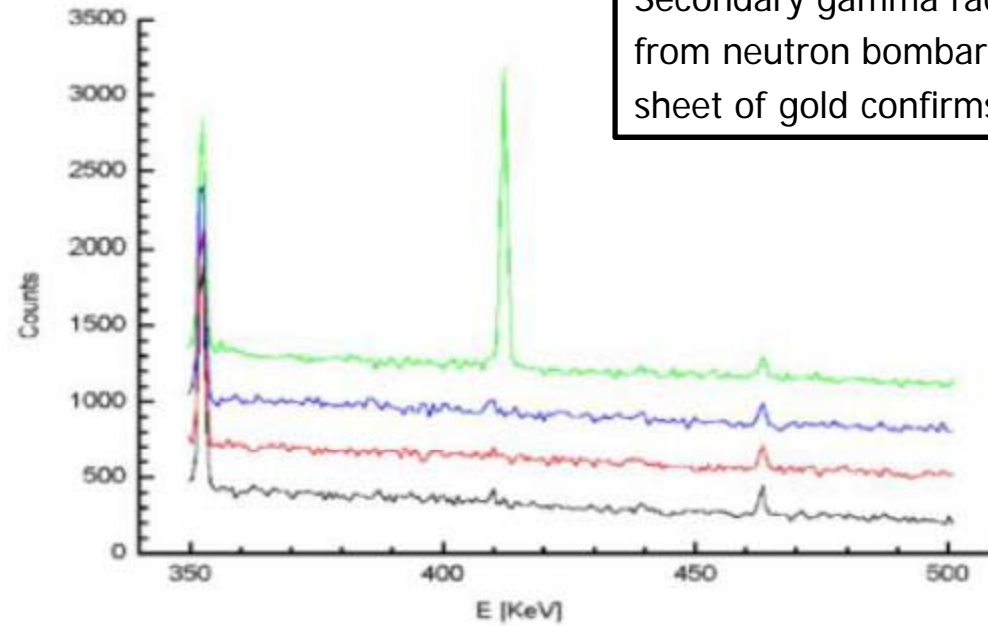

Secondary gamma radiation detected from neutron bombardment of a thin sheet of gold confirms neutron radiation



# Francesca Piantelli LENR Experimental Results

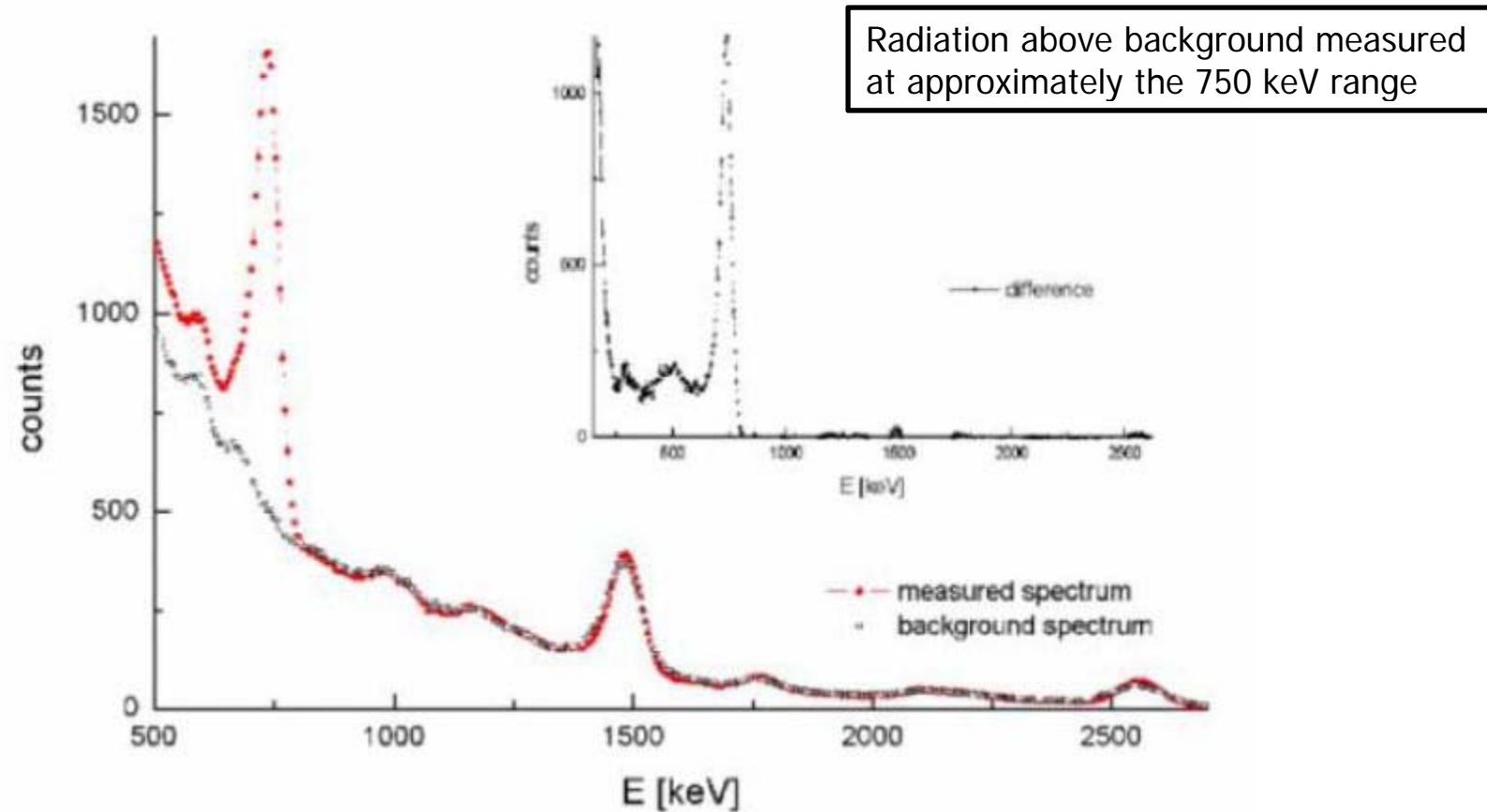



# Francesca Piantelli LENR Experimental Results



Particle path traces have been observed using a cloud chamber for days after a test sample has been removed from the test chamber



# Francesca Piantelli LENR Experimental Results

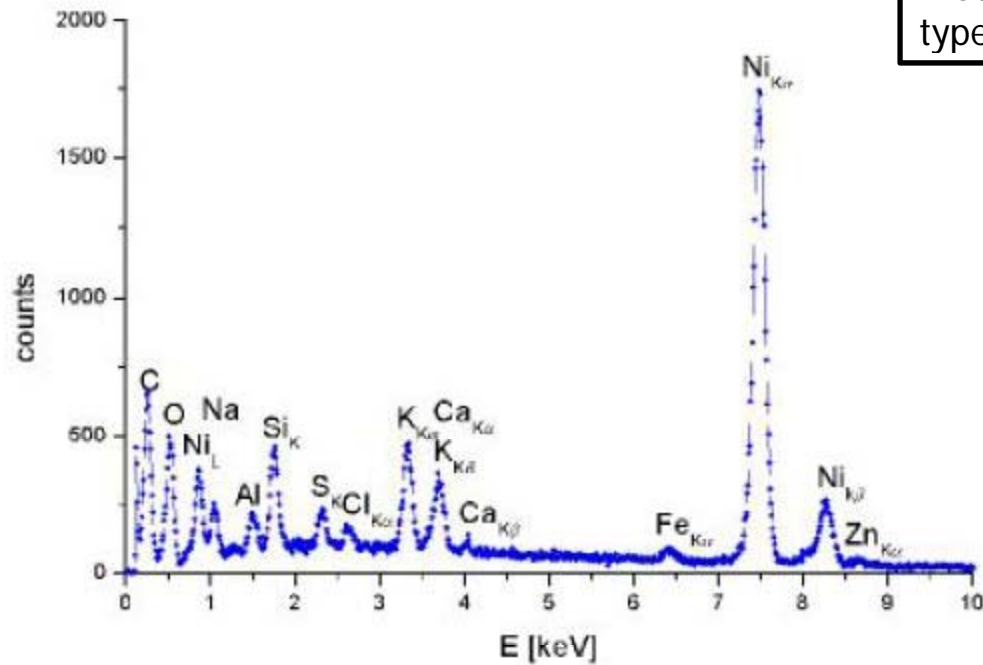

Products indicating both fusion and fission type of reaction may be occurring



# Francesca Piantelli LENR Experimental Results

---



Close up view of a site on the surface of a Nickel test sample that indicates transmutation of Ni into other elements





# Francesca Piantelli LENR Experimental Results



New test laboratory with  
400 square meters  
of work space opened in  
2004 near Siena



# Francesca Piantelli LENR Is it Nuclear...?

---



- Emission of Gamma Radiation has been indicated
- Emission of Neutron Radiation has been detected
- Emission of charged particles
- Transmutation of Nickel into other elements
- Excess heat exceeding known Hydrogen-Nickel chemical reactions



# Francesca Piantelli/Andrea Rossi LENR Comparison

---



- Rossi does not speak of a requirement for loading Hydrogen into the Nickel
- Rossi operates at a “sweet spot” of 24 atmospheres or ~350 psi where Piantelli operates at less than an atmosphere
- Rossi indicates that hydrogen is consumed to keep the reaction going and Piantelli does not
- Rossi indicates that he uses a catalyst to make the reaction repeatable and highly efficient (Piantelli also has a secret)
- Rossi utilizes a signal generator not indicated in Piantelli’s reports
- Both indicate they have seen gamma and neutron radiation
- Both indicate the transmutation of Nickel into other elements
- Both indicate excess heat exceeding known Hydrogen-Nickel chemical reactions



# Importance of this Technology to NASA

---



## Why is this so important?

- Technology demonstrated by Andrea Rossi or Francesca Piantelli is potentially a “game changer” for space propulsion and vehicle energy needs
  - Energy density many orders of magnitude over chemical
    - Lower propellant mass to transport into space
    - Reduces transit times on manned mission to MARS
  - Energy derived from non-radioactive components
    - Environmentally friendly
    - Safe to handle in ground processing
  - Radiation easily contained for crew safety
  - Nickel and Hydrogen abundantly available (lower cost)
  - Can be engineered for both space craft propulsion and vehicle power needs



## The Immediate Future...

---



- The first step is to complete basic testing of this technology to determine among many test objectives that it is indeed a nuclear reaction and begin to determine the energy multiplier of energy required to initiate the reaction and energy produced by the reaction.
  - This testing should confirm gamma and/or neutron radiation by repeatable observations
  - This testing should demonstrate that energy produced exceed levels of any known chemical reaction of an equivalent test article mass
  - Successful results will lead to further investment into and development of the technology
  - This should be completed by early 2012 if not sooner if testing can start in the near future
  - This effort will be a collaborative effort between Glenn Research Center, Langley Research Center, Marshall Space Flight Center



## The Future starting latter half of Next Year...

---



- Second step will be to begin to expand on the science behind the technology with tests designed to explore perturbations of control variables that have yet to be examined
  - Continue work independently and in parallel in multiple locations
  - Begin to explore improvements to the technology
    - Is there a better process for repeating results?
    - Can it be scaled up?
    - What are the operating sweet spots of the technology?
  - Included industry consortia into collaborative effort between Glenn Research Center, Langley Research Center, and industry consortia



## The Future in the Years Ahead...

---



- Third step will be to begin building prototype applications and testing them based on a thorough knowledge of the technology
  - Propulsion systems for deep space
  - Propulsion applications in LEO (eg. Space Station Boost)
  - Power systems for vehicle in flight operations
  - Power systems for deep space and planetary probes
  - Power systems for human life support systems in flight
  - Power systems for human life support and operations on the Moon or Mars
  - Ultimately one or more NASA programs would be set up to implement this technology into a variety of space applications



## Follow Up



- 
- There are currently numerous resources on the Internet about Andrea Rossi and his technology. A search of Youtube will bring up many videos about him and this technology. Here are a few links to get your started.
  - <http://www.youtube.com/watch?v=xRry6a3U0Cw>
  - <http://www.youtube.com/watch?v=m-8QdVwY98E>
  - <http://www.youtube.com/watch?v=0cwSFu1Pz0g>
  - <http://www.youtube.com/watch?v=EDv6phew-ck>
  - <http://www.youtube.com/watch?v=NzL3RIlcwbY>
  - <http://www.newenergytimes.com/v2/news/2011/37/NET370.shtml>





## Follow Up (cont'd)



- 
- Also, these bullets link to a 60 Minutes story by Scott Pelley which will catch you up on what has been going on with cold fusion since Pons and Fleishman.
  - <http://www.youtube.com/watch?v=qb-9keOk-CQ&playnext=1&list=PLF55D9121F1815C24>
  - <http://www.youtube.com/watch?v=9f18W2SejEM&playnext=1&list=PLF55D9121F1815C24>
  - <http://www.youtube.com/watch?v=cgRiTphJRkg>
  - <http://www.youtube.com/watch?v=rLhqYFyrtWQ>
  - <http://www.youtube.com/watch?v=SBVcA6G35QY>



## Highlights of Recent History of LENR with Andrea Rossi (Prior to 2011)

---



- April 9, 2008 – Rossi filed Italian Patent Application
- August 4, 2008 - Rossi filed international patent application.
- November 19, 2009 – Rossi demo'd in Bedford, New Hampshire USA to current or former affiliates of the Department of Energy
- Nov. 20, 2009 Rossi demo'd in Bedford, New Hampshire USA to current or former affiliates of the Department of Defense
- 2010 Naval Research Laboratory researchers visit Rossi in New Hampshire and see demonstration. (Source: Navy researcher)
- Feb. 26, 2010 - Rossi's "Journal of Nuclear Physics" domain name registered.



## Brief synopsis of LENR History

---



- “Cold Fusion” phrase coined in 1989 with the announcement of excess heat in experiments involving Deuterium and Paladium conducted by Pons and Fleishman
  - Results were not easy to replicate and evidence for “Fusion” was lacking. Main stream interest and funding dried up.
- Later in 1989, an Italian scientists named Dr. Francesca Piantelli observed anomalous energy emerging from a Nickel sample in a Hydrogen environment and began studying NI-H low energy nuclear reactions.
- In spite of the difficulties of replicating results, work continued under the new name of Low Energy Nuclear Reactions (LENR). Experiments were conducted in the US (funded by the US Navy) and abroad over the past 20 years.
  - Development led by Italy, Japan, France, India, US (very low level)